

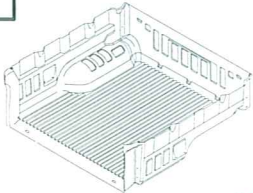





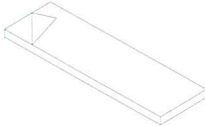
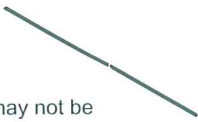

INSTALLATION INSTRUCTIONS (K553)

Ford-Ranger T6-2011-Extra Cab-Under Rail Liner

A  X1	B  X1	C  X6	D  X10
E  <p>⚠ This part may not be included for some markets</p> X1	F  X4	G  M8x20mm X8	H  M6x16mm Pan Pozi X8 M6x19mm Washer X6

◊ = EXISTING PART ○ = NEW PART

1

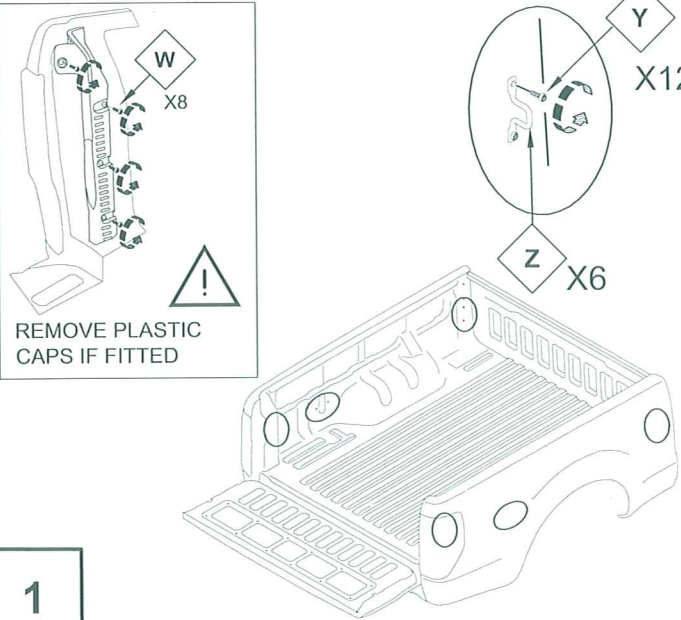

W X8

Y X12

Z X6

REMOVE PLASTIC CAPS IF FITTED

2

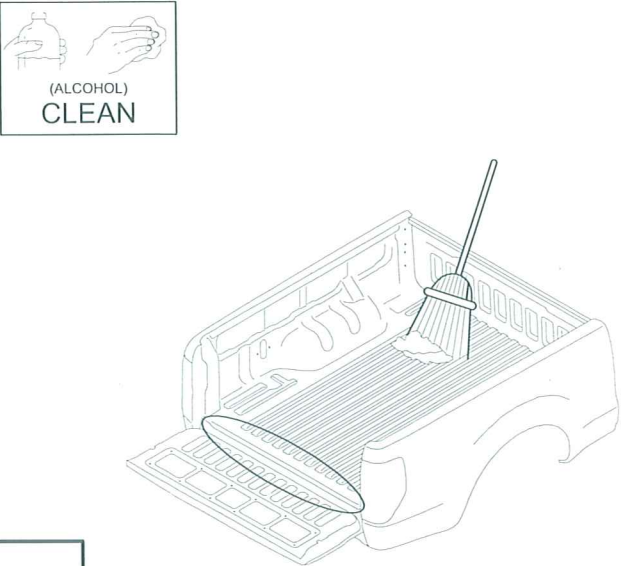

(ALCOHOL) CLEAN

3

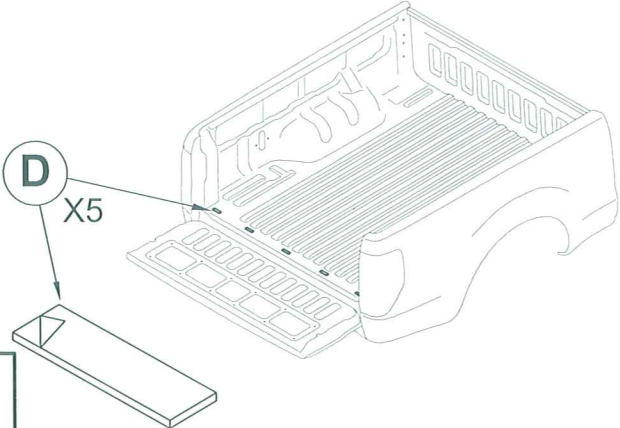

D X5

4

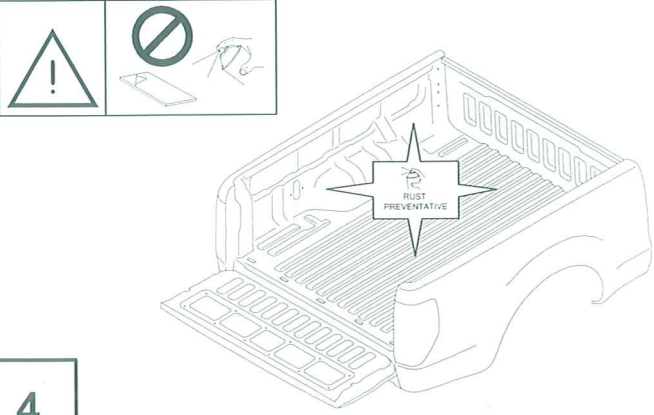

RUST PREVENTATIVE

Fitting Kit Number	Manufacturer	Model Type	Year	Stockist	Cab Size	Product	Revision	Date	Page
IDFK553	Ford	Ranger	2011	General Use	XC	UR Liner	1	30.11.11	1 of 3

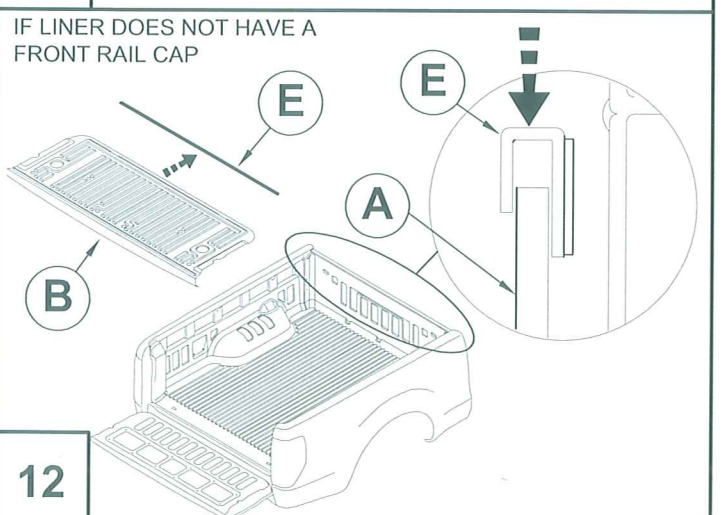
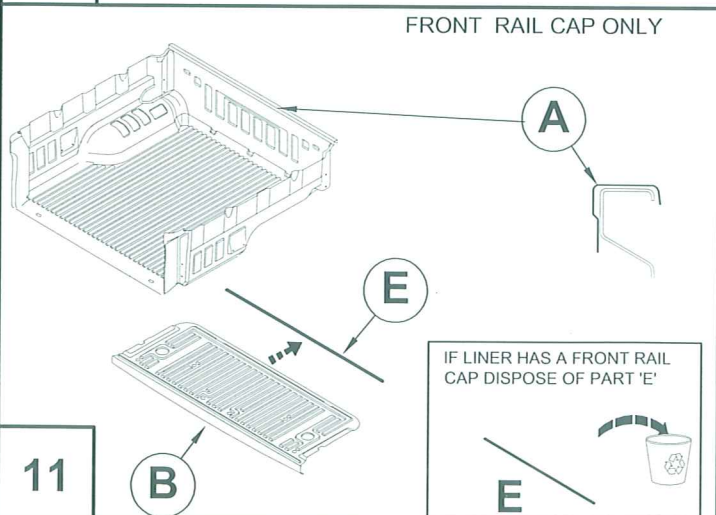
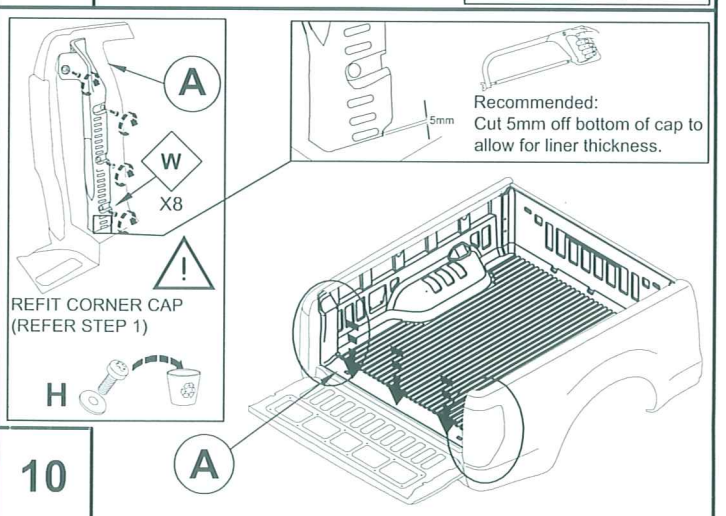
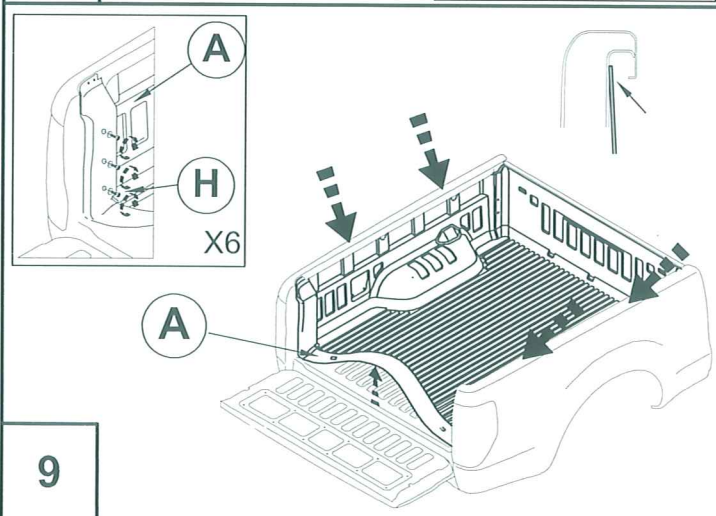
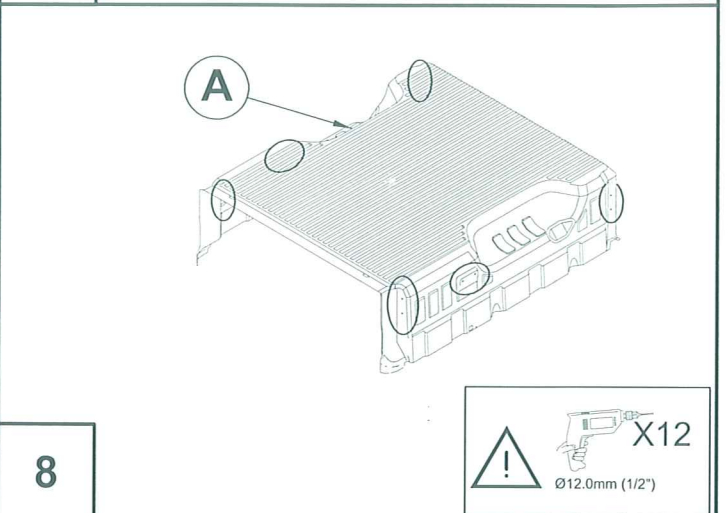
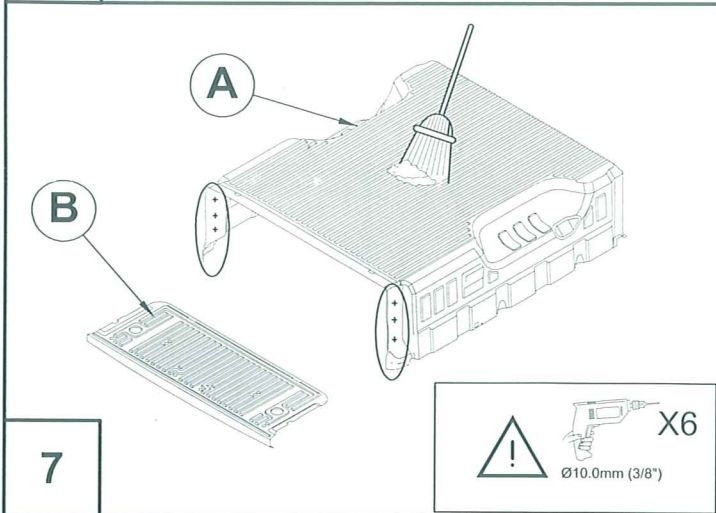
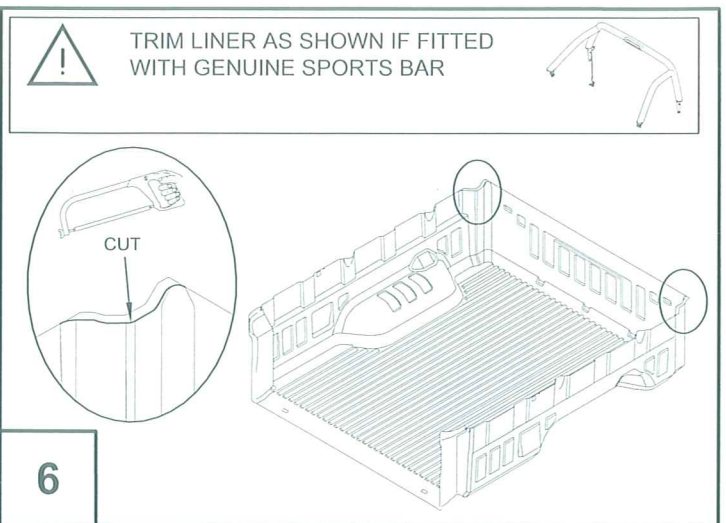
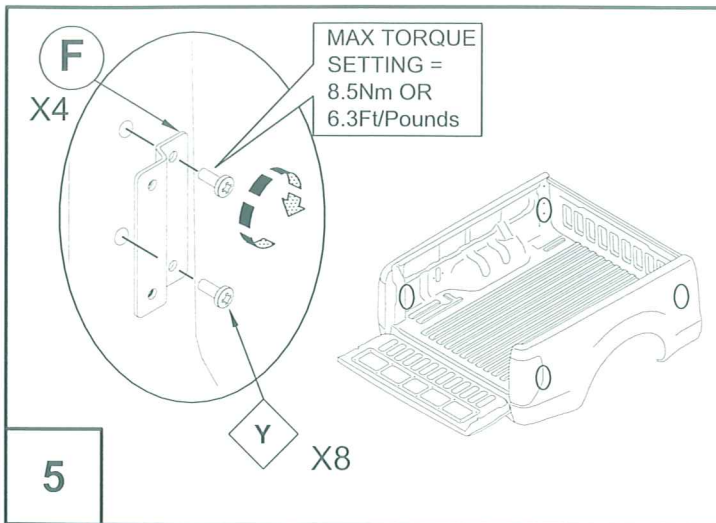

Fitting Kit Number	Manufacturer	Model Type	Year	Stockist	Cab Size	Product	Revision	Date	Page
IDFK553	Ford	Ranger	2011	General Use	XC	UR Liner	1	30.11.11	2 of 3

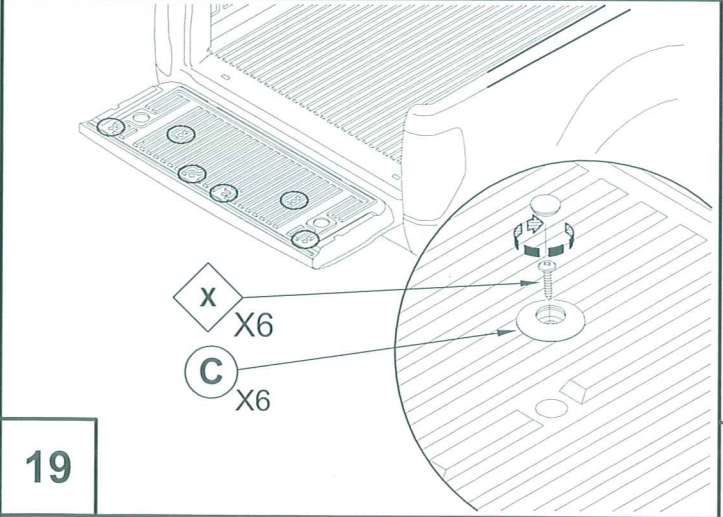
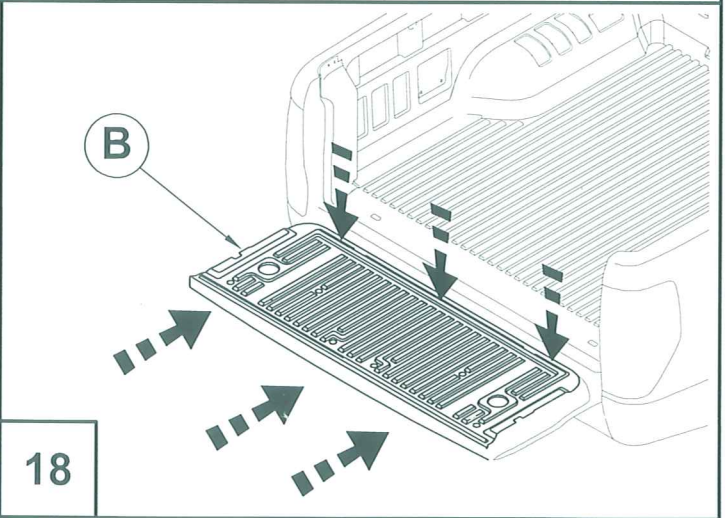
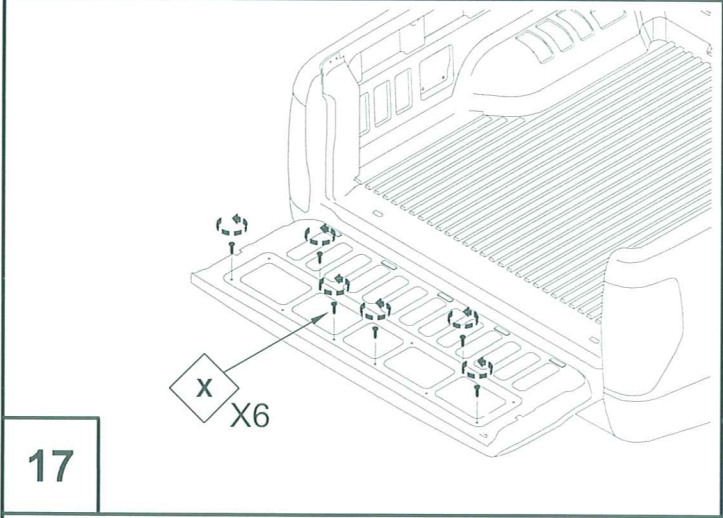
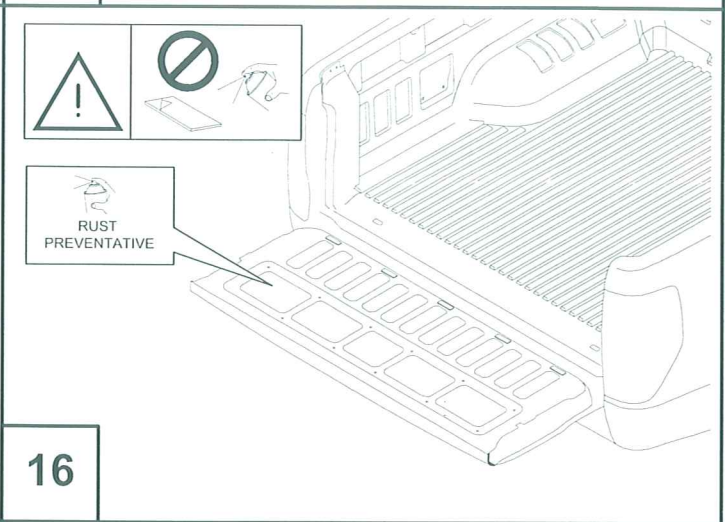
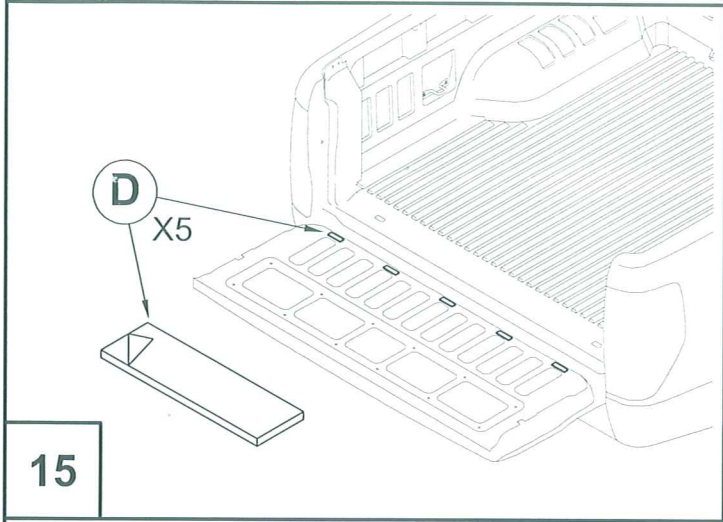
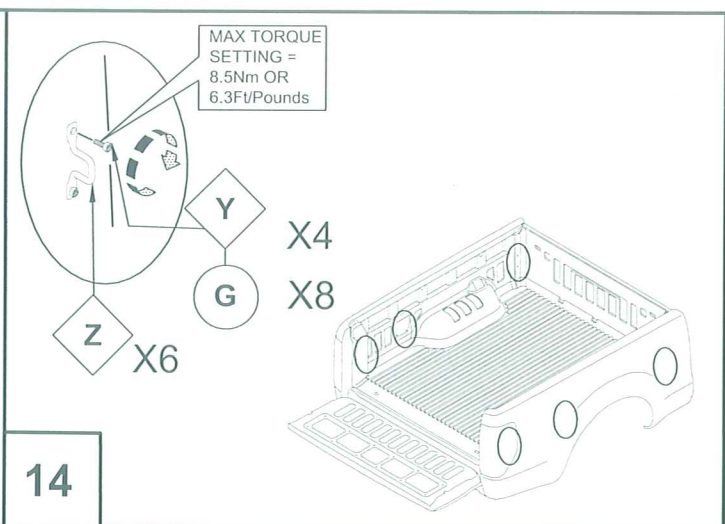
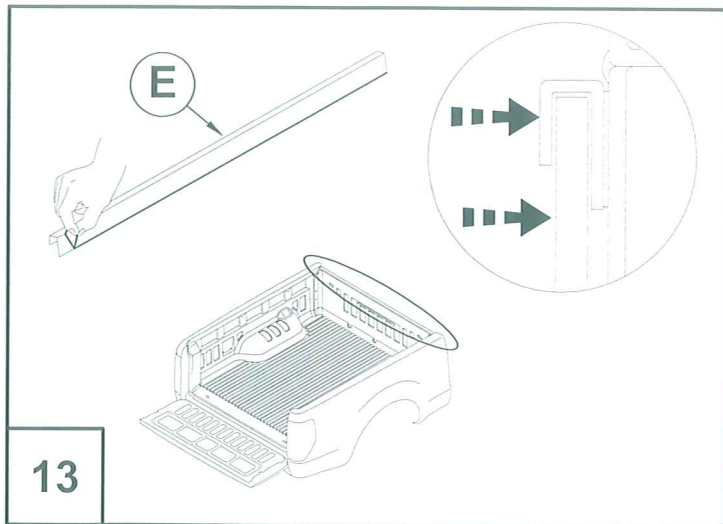

Fitting Kit Number	Manufacturer	Model Type	Year	Stockist	Cab Size	Product	Revision	Date	Page
IDFK553	Ford	Ranger	2011	General Use	XC	UR Liner	1	30.11.11	3 of 3