

INSTALLATION, MAINTENANCE and USER`S MANUAL RAD, RADC, RAK and RAKC.

Before starting the installation, read the entire Installation Instruction carefully!!!

1 INSPECT THE INSTALLATION KIT!

The installation kit includes:

- 6 pcs Clamps
- 1,5 m Protective tape



Fig. 1

2 START INSTALLING THE HARDTOP ONTO THE TRUCK BED

First clean the truck bed frame, open hardtop back hatch and lift the hardtop carefully on the car bed. (Fig. 2)



Fig. 2



Fig. 3

Mount the hardtop lower-rear corner aligned with the cargo bed rear corner! (Fig. 3)

3 ATTACH THE HARDTOP TO TRUCK BED

Center the hardtop sideways on the load bin and place the clamps acc. to the image. (Fig. 4)



Fig. 5

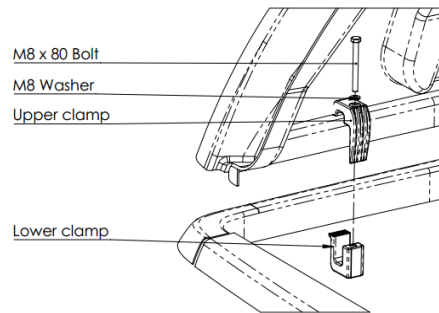

Fig. 4

Pull the cover towards the edge of the bin with 6 clamps (Fig. 5)

NOTE! Tension force Max. 10 Nm or 1kg/m

If over rail plastic bed liner (Fig. 6) is used it is necessary to drill holes for the clamps.



Fig. 6

5 INSTALL PROTECTIVE TAPE ON THE CAR TAILGATE

Cars without protective cover clean the car tailgate where the hardtop back hatch sealing touches the car tailgate (Fig. 7) and fasten protective tape to that part.



Fig. 7

5 ADJUSTING THE HATCHES

RADC, RAKC -0055; -1155; -1133

Check that the doors close easily and that the lock is correctly adjusted, if necessary adjust the lock or locking strap. (Fig. 8)

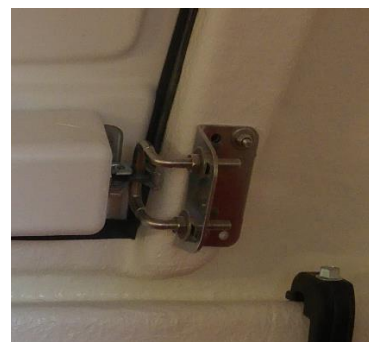

Fig. 8

It is possible to adjust the length of the locking rods by loosening the plastic clip and turning the locking rod which is screwed into the joint against the locking hook. (Fig. 9)



Fig. 9

RAD, RAK -0055,-1155; -900; -1100

Check that the doors close easily and that the locks are correctly adjusted. If necessary, the height of the glide angle can be adjusted (Fig. 10)



Fig. 10

6 INSTALLING RAILINGS OR ROOF RACKS

Install railings or roof racks on to the roof of hardtop flat surface (Fig. 11) according to the railing or roof rack layout drawings.

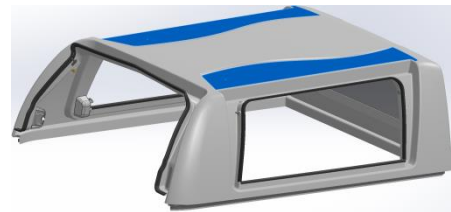

Fig. 11

To fasten railings (Fig. 13) or roof racks (Fig. 12) drill holes and fasten according to drawings.

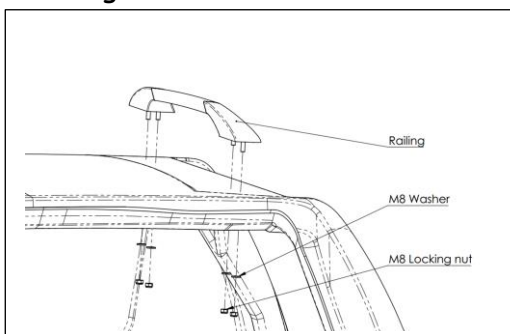

Fig. 13

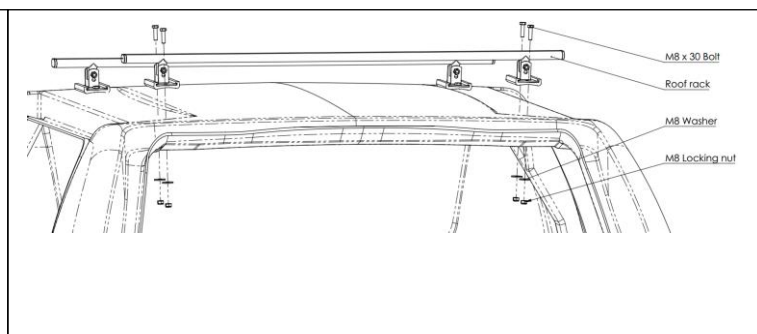

Fig. 12

NB!!! It is not allowed to step on to the roof!

7 MAINTENANCE

- ✚ To ensure that the door lock system's moving parts function correctly, lock systems should be lubricated at least twice per year. Under difficult conditions such as a dusty environment, then every month is recommended
- ✚ Our recommendation is to wax the hardtop with gel coat surface when new, mounted on the vehicle, and then annually to avoid discoloration. Read more: "Maintenance instructions for a hardtop with gel coat surface".
- ✚ A pressure washer can be used to wash the inside of the hardtop.
NB!!! Beware of electrical appendices!

NB!!! After driving for approximately 6-8 months all connections should be checked and re-tightened, if necessary!!!