

# CENTRAL LOCK INSTALLATION USER'S MANUAL IDC and IELC.

Before starting the installation, read the entire Installation Instruction carefully!!!

Please be careful when connecting wires!!!

- 1** Remove the left rear light!

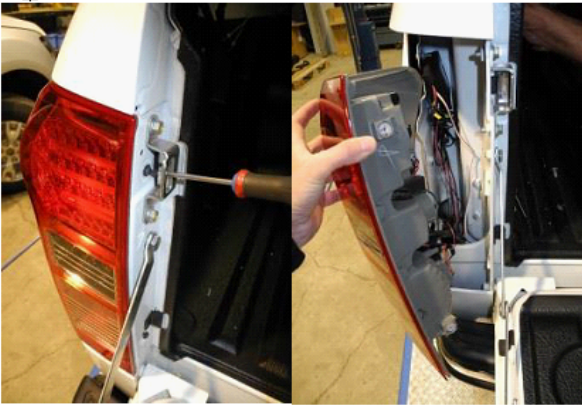

Fig. 1

- 3** Feed black and red cables near to battery (Fig. 2) and connect black wire to (-) and red to (+).

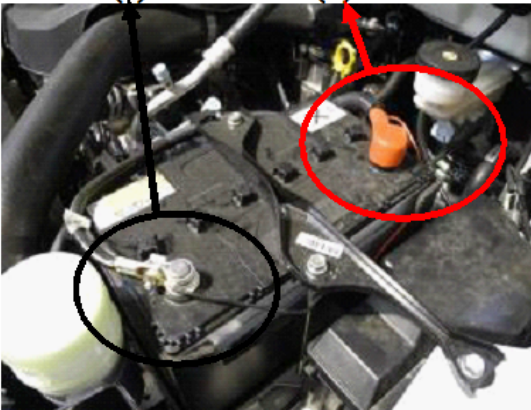

Fig. 2

- 5** Feed the cable through brake into the cbine! (Fig. 5 and Fig. 6)



Fig. 6

Fig. 6

- 2** Feed long cable from hardtop relay through car brake light and along the chassis towards the front of the truck (Fig. 3) to motor room and connect wires according wiring diagram! Follow car original wires and attach wire with clips.

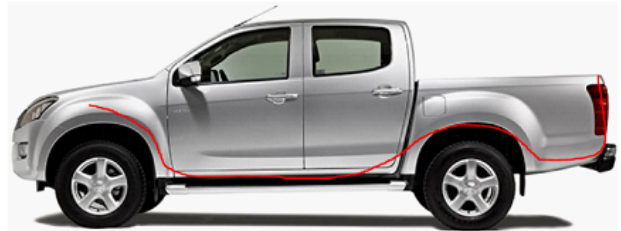

Fig. 3

- 4** Connect grey cable from hardtop to brake light red wire (Fig. 4)

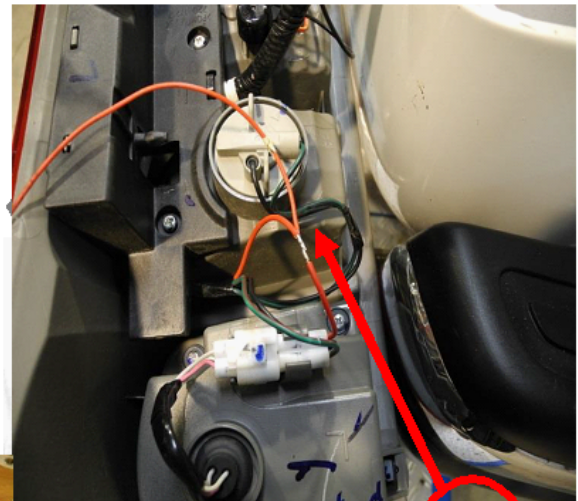

Fig. 4

**6** Locate the plug indicated in the drawing (Fig. 7) where the car central lock cables are and connect blue and blue/red cables on vehicle loom to white and another to brown. Test and change when hardtop lock does not work correctly!

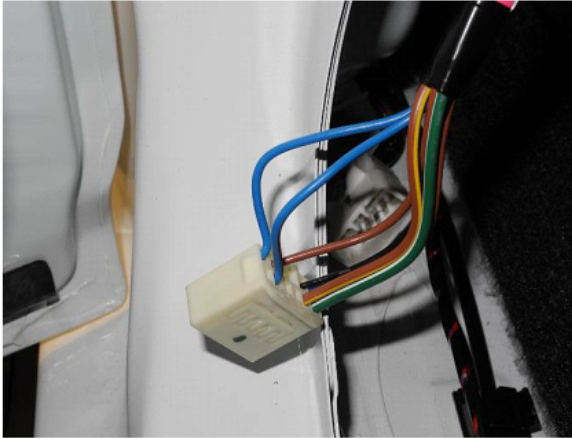

Fig. 7

**7** Re-install the left rear light! (Fig. 8)

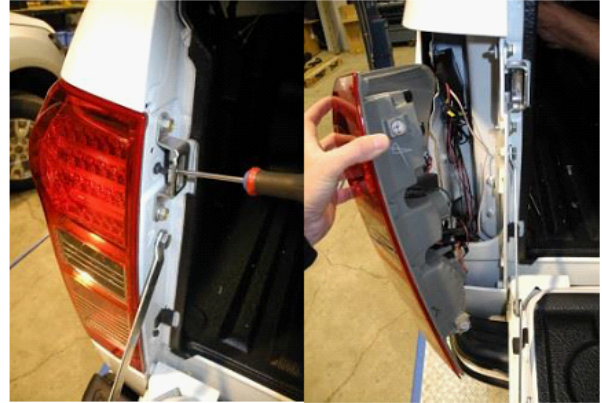

Fig. 8

**8** When connecting wires it is recommended to use electrical tester to get correct fitting. When testing cables you should get a 12v flash reading when pressing the central locking. Cover any connection with electrical tape and keep away cables from heat sources such as exhaust system.

**It is strongly recommended that installation is done by licenced Auto Electrician!!!**

**Any electrical faults due to improper installation will not be warranted by PLB Vindic AB!!!**



This drawing is the property of PLB Vindic AB. It is strictly confidential and must not be copied, traced or loaned without permission. Any infringement of these conditions will lead to the institution of legal procedures

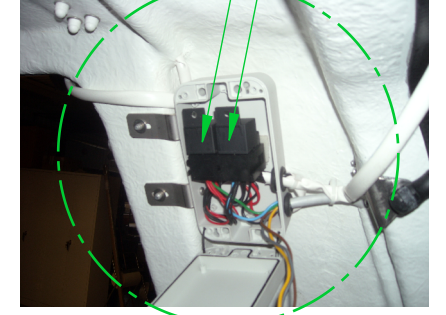
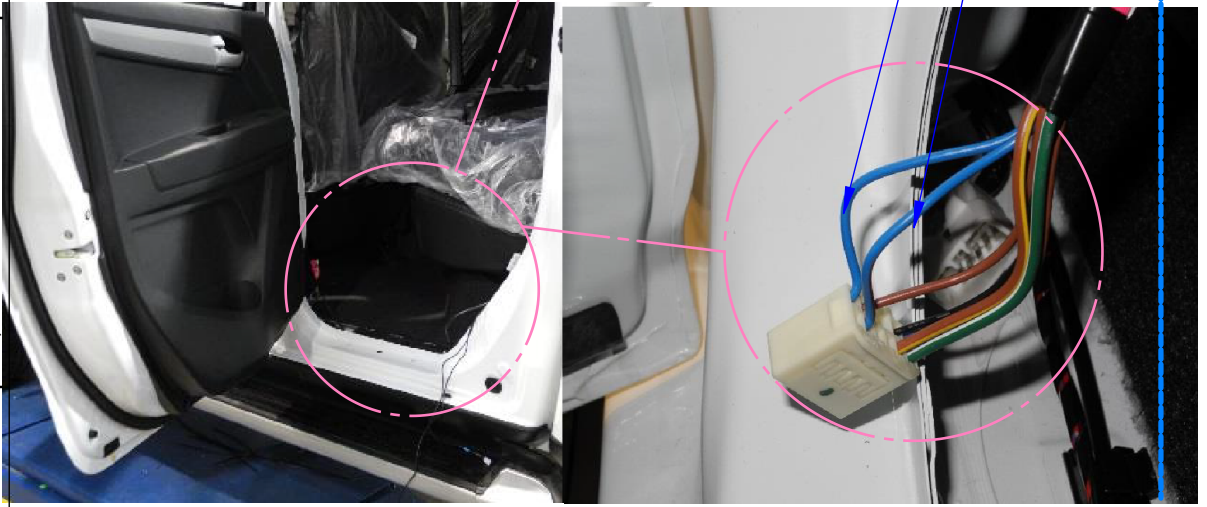
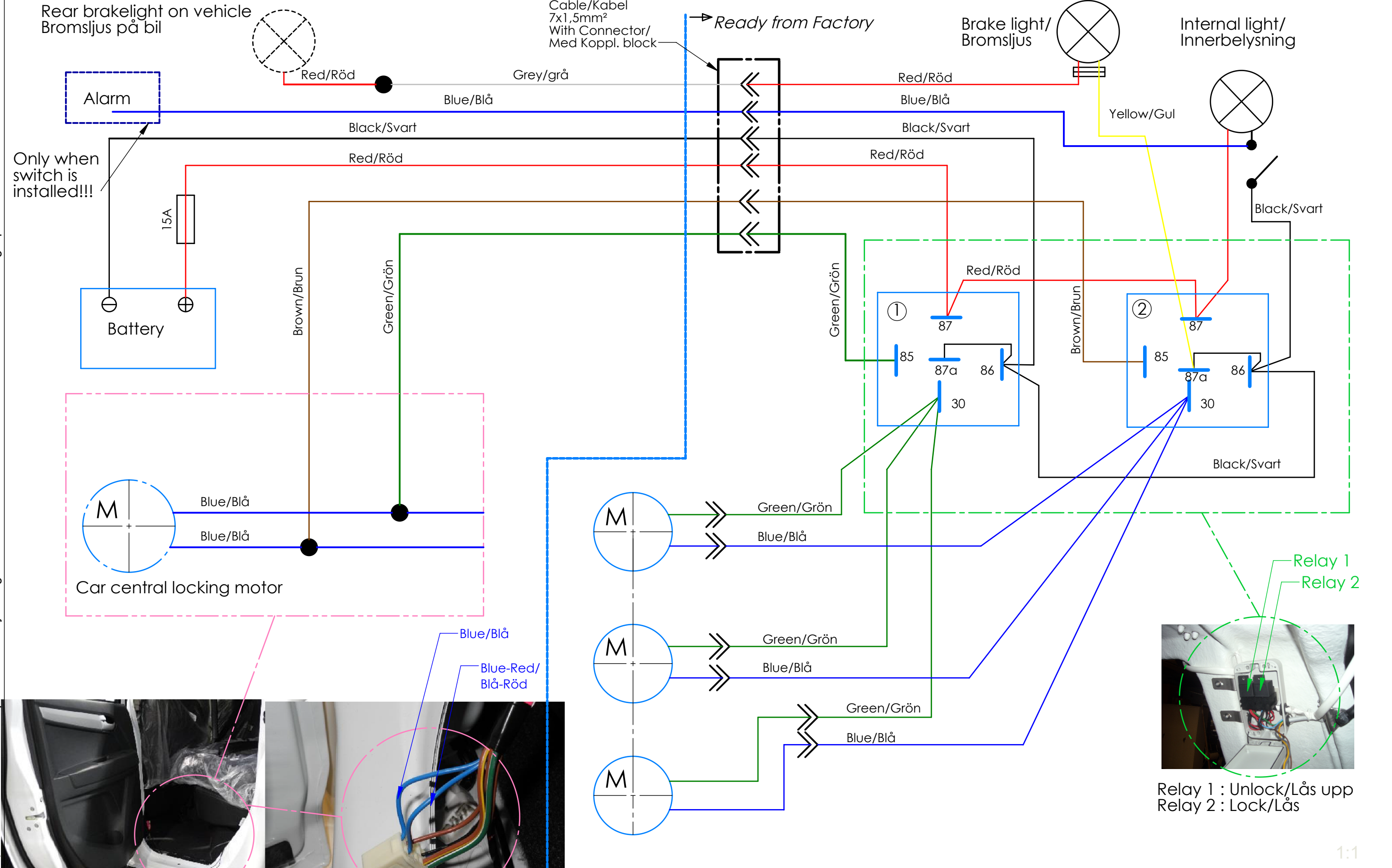

Relay 1 : Unlock/Lås upp  
Relay 2 : Lock/Lås

● =Soldering/Lödning

Designed by: S. Ennemuist	Title/Name:	
Date: 22.05.2017	Central locking wiring diagram IDC/IELC-55	
Owner: <b>PLB VINDIC</b> PLB Vindic AB Sweden	Sheet: 3/3	Drawing number: 80-4404 IDC/IELC-55